

DESCRIPTION	446-L	466-L	496-L	4126-L	4156-L
LIFTING BAIL	3237	3238	3239	3240	3241
BAIL PIVOT BOLT	3250	3250	2678	2678	2678
BAIL PIVOT BOLT NUT	1761	1761	3065	3065	3065
BAIL PIVOT BUSHING	3246	3246	3247	3248	3249
BAIL PIVOT BOLT WASHER OUTER	0203	0203	0274	0274	0274
BAIL PIVOT BOLT WASHER INNER	0203	0203	1220	1220	1220
BAIL SAFETY BOLT	2704	2704	2703	1626	1626
BAIL BOLT NUT	2245	2245	2245	1181	1181
BAIL BOLT WASHER	2404	2404	2404	2185	2185

WHEN ORDERING PARTS, SPECIFY:

1. THIS DRAWING NO: 01-55
2. PART NUMBER
3. QUANTITY
4. DESCRIPTION

PART #	DESCRIPTION
3283	THREAD LOCKING CMPD
3000	"G" GATE REPAIR KIT
2289	"G" GATE COMPLETE
2288	GATE LEVER
1834	GATE PLATE/ R ARM ASSY
1815	PIVOT BUSHING
1814	SPRING SPACER
1476	PIVOT BOLT
0359	GATE SPRING
0169	HEX NUT
0118	GATE SPRING BOLT
0114	HANDLE BOLT
0019	LOCKWASHER

△ INCLUDED IN PN 3000 REPAIR KIT

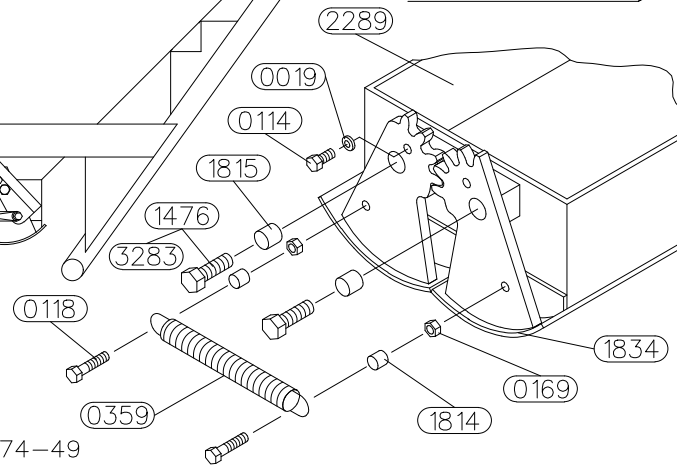
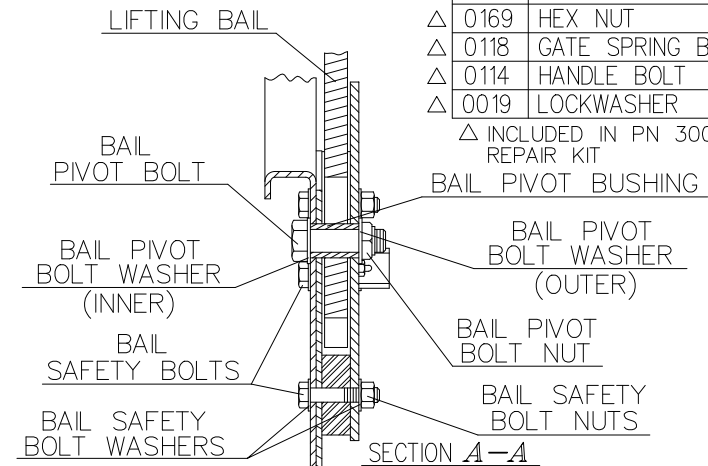
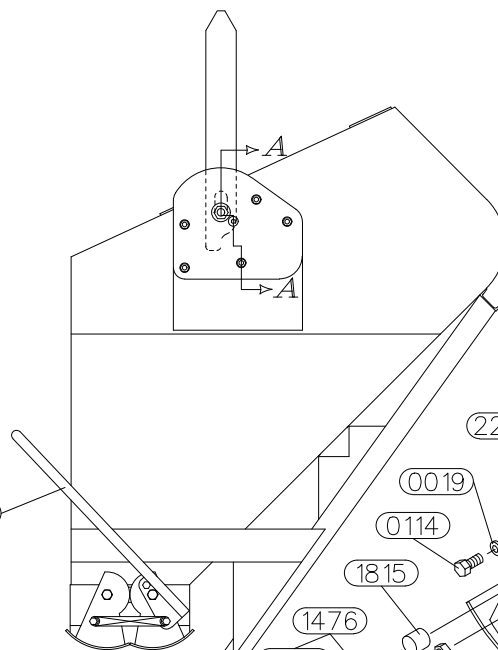
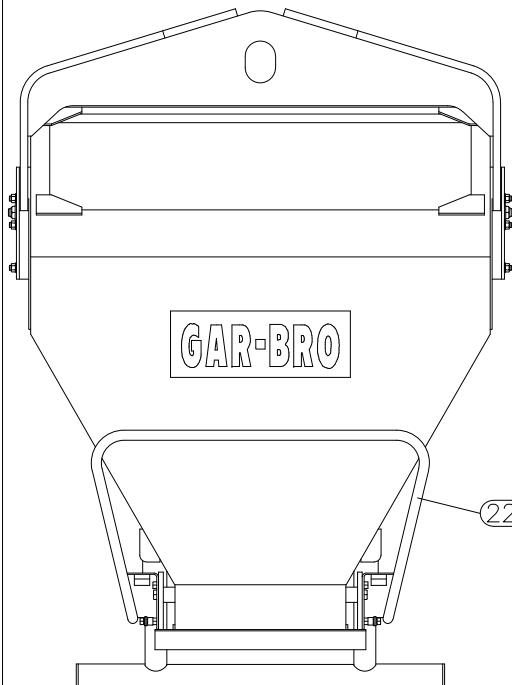

GAR-BRO MANUFACTURING CO.
104 BOLTON SULLIVAN DRIVE P.O. DRAWER 1077
HEBER SPRINGS, ARKANSAS - 72543-1077

**ITEM 446-L THRU. 4156-L
"L" SERIES LIGHTWEIGHT
LAYDOWN BUCKET
WITH NEW STYLE BAIL
PARTS LIST**

FOR BUCKETS MANUFACTURED AS FOLLOWS:
ITEM 446-L BUILT AFTER NOVEMBER 1998 S.O. 10569
ITEM 466-L BUILT AFTER SEPTEMBER 1992 S.O. 6579
ITEM 496-L BUILT AFTER OCTOBER 1991 S.O. 6071
ITEM 4126-L BUILT AFTER FEBRUARY 1993 S.O. 6815
ITEM 4156-L BUILT AFTER MAY 1996 S.O. 8779

FOR ALL OTHER "L" SERIES BUCKETS, SEE DRAWING 74-49

SCALE	NONE	SHOP NO.	SALES
DATE	7-9-01	SHIPPING	CUBICS
REVISED	9-1-11	DRAWING NO.	
MADE BY	JPA	01-55	
CHANGED TO/FROM		SHEET A OF A	
SUPERSEDES			